

PS50 Plasma Swivel Bracket

Technical Sheet

Sheet 1 of 4
 ISSUE: 003
www.futureautomation.co.uk

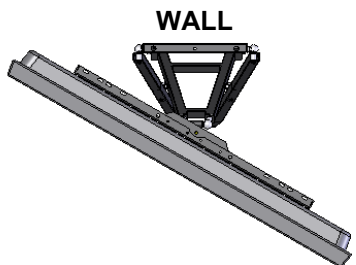

VIEWS FROM ABOVE
 SHOWING ACTION

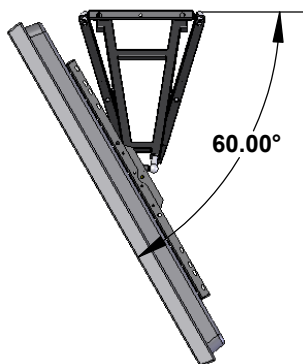

ANGLE CAN BE REDUCED
 ON VERY WIDE SCREENS

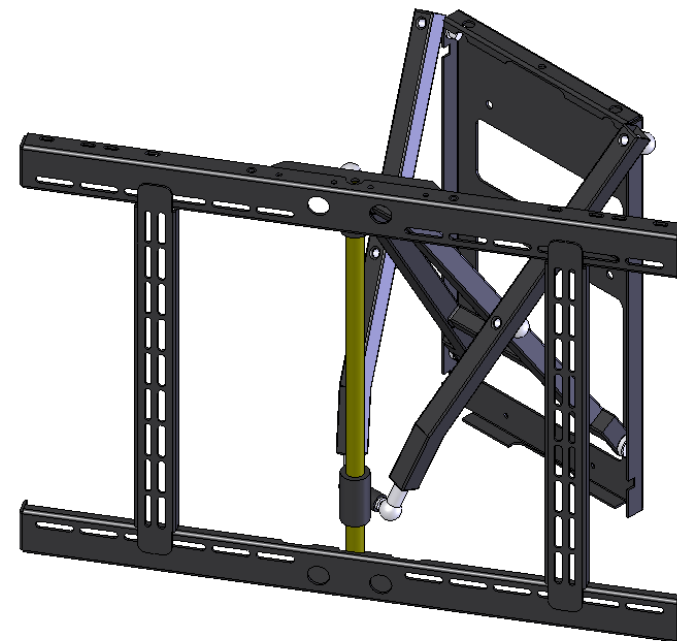

VERY SMOOTH ONE
 HANDED OPERATION

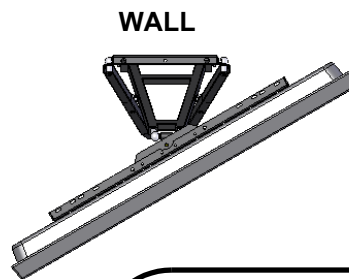
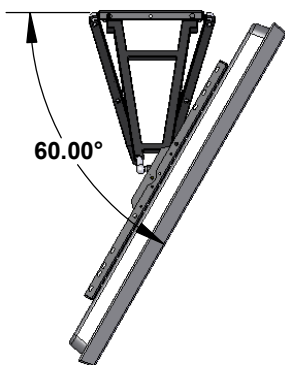

SWINGS BOTH WAYS

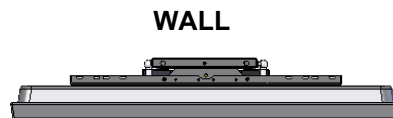

WARNING

It is the responsibility of the installer to make sure this product is safely secured to the wall or ceiling.

FUNCTION

A swivelling manual plasma bracket for screens from 37" upwards. Pull away from the wall and swivel the plasma screen left or right.

There are three sizes available.

SUITABILITY

All screens in our 'Group A' will fix straight on to the PS42. 'Group A' 50" plasmas fit the PS50.

Custom PS60 also available for popular 60" to 65" screens.

SPECIFYING

Check the wall make up for suitability.

Check viewing angles and position.

WALL FIXINGS

No fixings are provided with this product. Consider using rawbolts or resin anchors. Resin anchors are ideal for softer brickwork or blocks.



FUTUREAUTOMATION

PS50 Plasma Swivel Bracket

Technical Sheet

Sheet 2 of 4
 ISSUE: 003
 www.futureautomation.co.uk

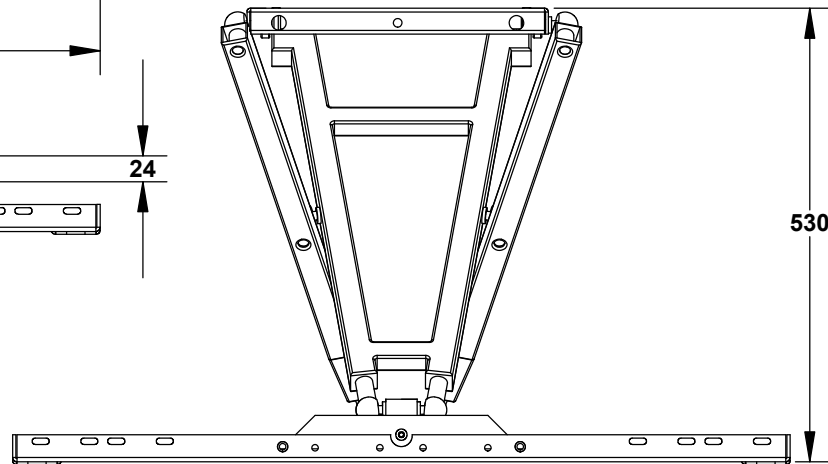
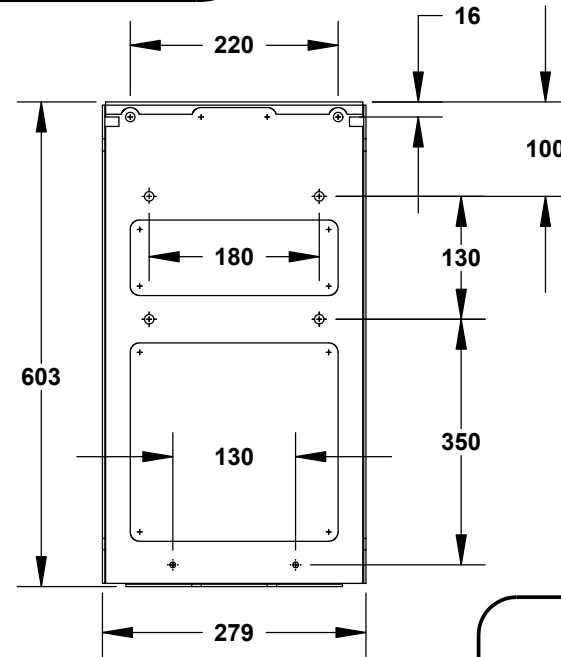
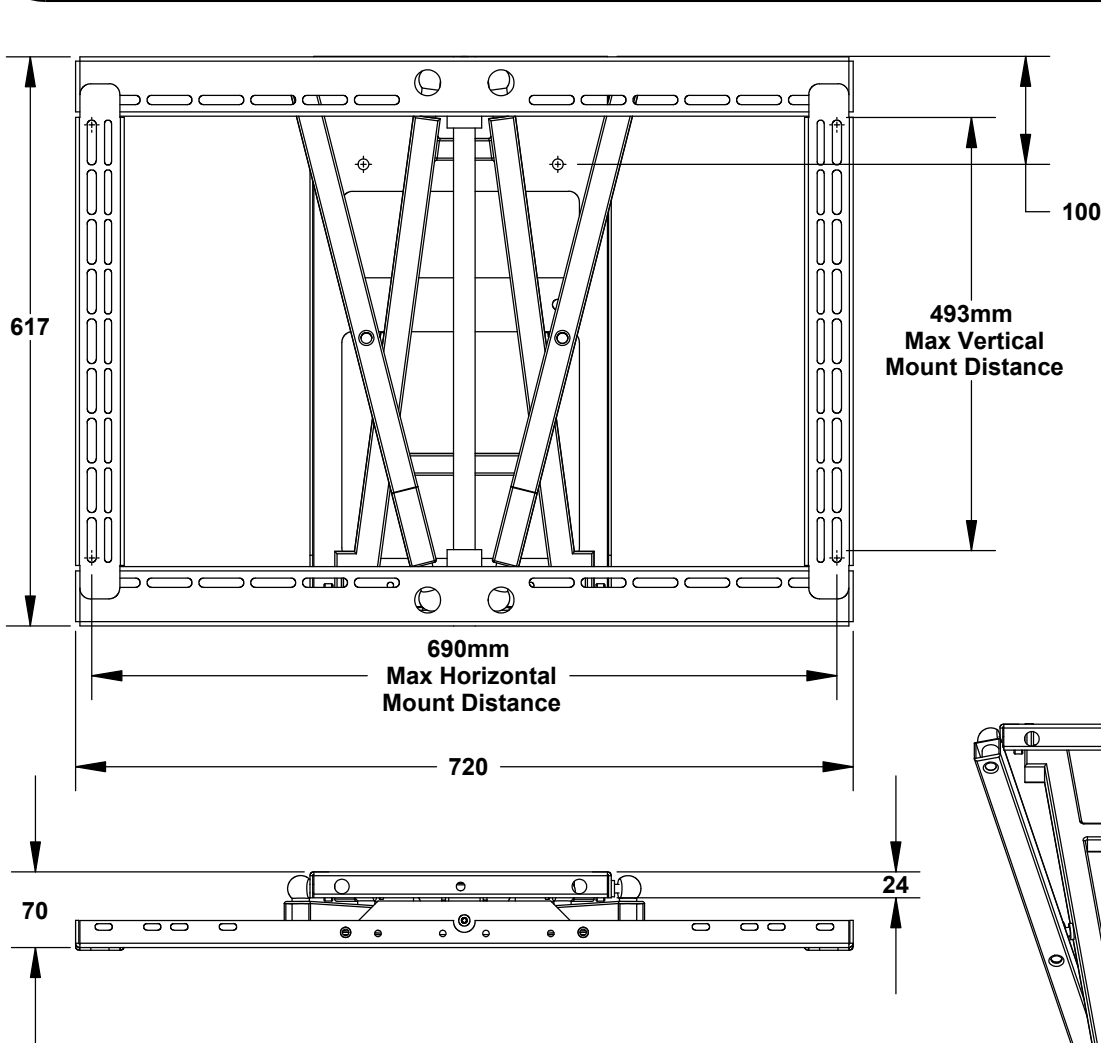

FIXING

Fix wall plate to wall
 Fix frame to plasma screen
 Hang plasma on wall mounted frame

FIXING

6 main fixing holes on the wall plate

The main pulling force is at the top of the wall plate.

Wall plate must be fixed on a strong, solid surface.

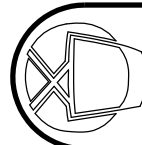

FUTUREAUTOMATION

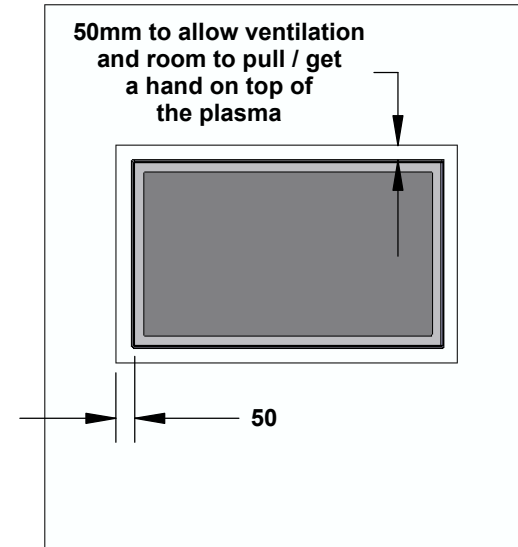
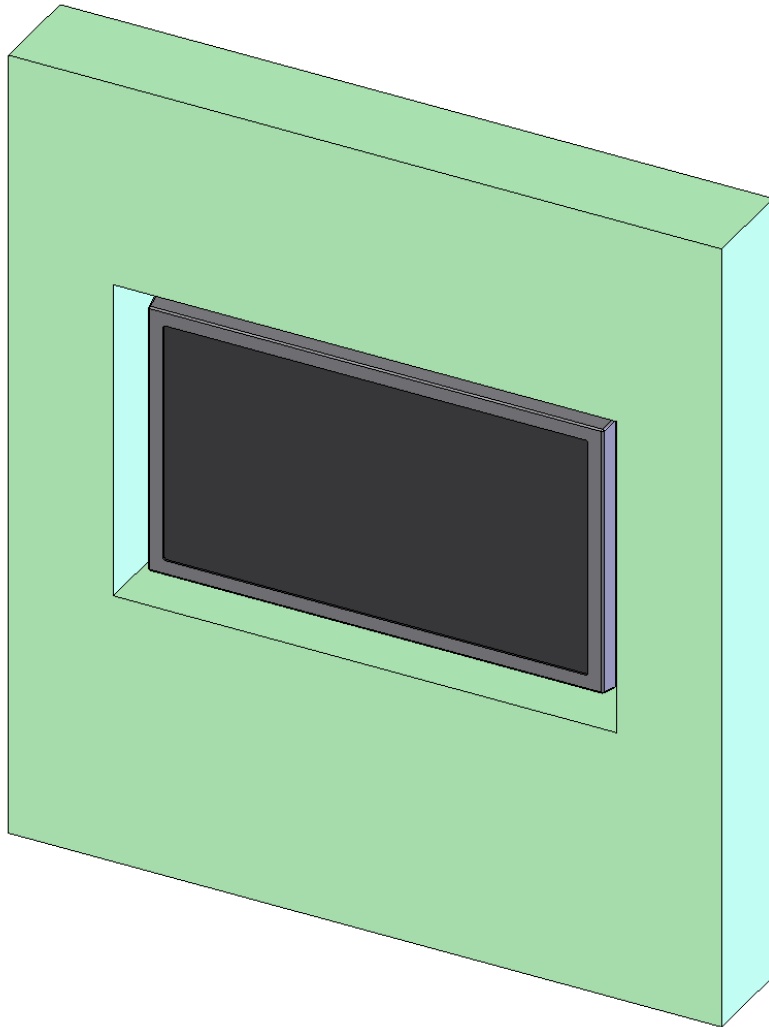

When recess mounting a plasma on a Future Automation Swivel Bracket the gap around the edge could be as little as 3mm. Ventilation would have to be provided by opening the top and maybe the bottom of the recess.

Larger gaps of 50mm around the plasma screen enable some ventilation and enough room to grab hold of the plasma to pull it out.

With the add on motor kit a gap of at least 20mm is required on each side with at least 10mm top and bottom.



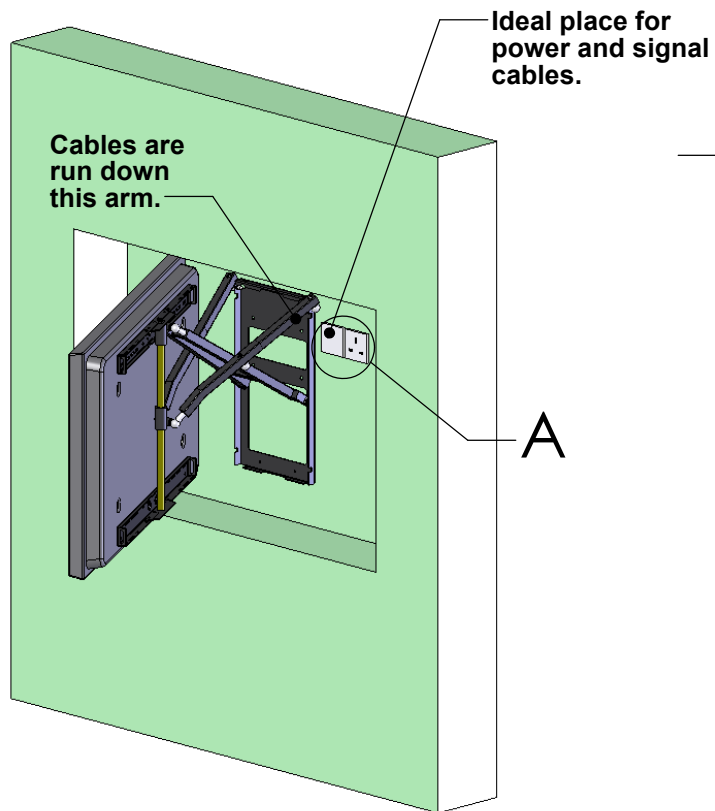

WALL PLATE

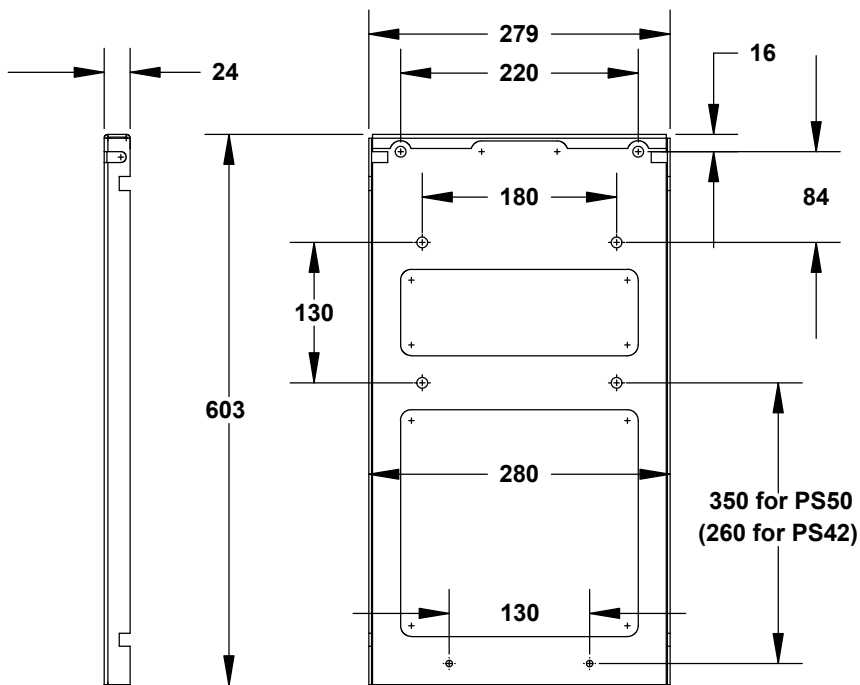

Depth of recess should be screen depth + 70mm for bracket + 10mm spare.

With the add on motor kit allow 95mm + screen depth.

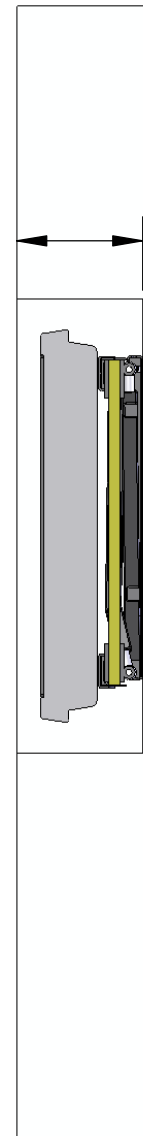

The whole area of the wall plate needs to be well supported. Ideally solid plaster over brickwork. If stud work then thick timber (50mm) to screw into around the top six mounting holes. The lower part of the wall plate needs to be over 18mm ply/MDF as the bearings shown on the sketch on the left push with some force into the wall.

